



DENALI Plow Mount MA11104 Polaris Sportsman 550/850XP

Thank you for purchasing our DENALI plow mount. You now own a premium custom plow mount to allow you to use your plow with your ATV. Please note the following instructions and heed all warnings.

- Your ATV and/or plow system can cause death or injury, please use caution and common sense when operating your unit.
- Read your Plow Operator Manual, your Winch Operator Manual, and all warning labels before operating your ATV.
- Operate your ATV at a walking speed with the blade installed. Do not exceed 5 mph (8 km/h), even with the blade up.
- Do not operate the ATV on slopes greater than 10 degrees with the plow installed.
- Always lower the plow to the down position before leaving your ATV unattended.

SEVERE INJURY OR DEATH MAY RESULT IF YOU ARE NEGLIGENT.

Please verify that all hardware and parts are included in your package.

Kit Contents:

Item Number	Description	Quantity
1	Base Plate	1
2	Flat Hold Down	1
3	Angled Hold Down	1
4	5/16" x 2 1/2" U-Bolt	2
5	5/16" Washer	8
6	5/16" Nylock Nut	6
7	5/16" x 2 1/2" Bolt	2

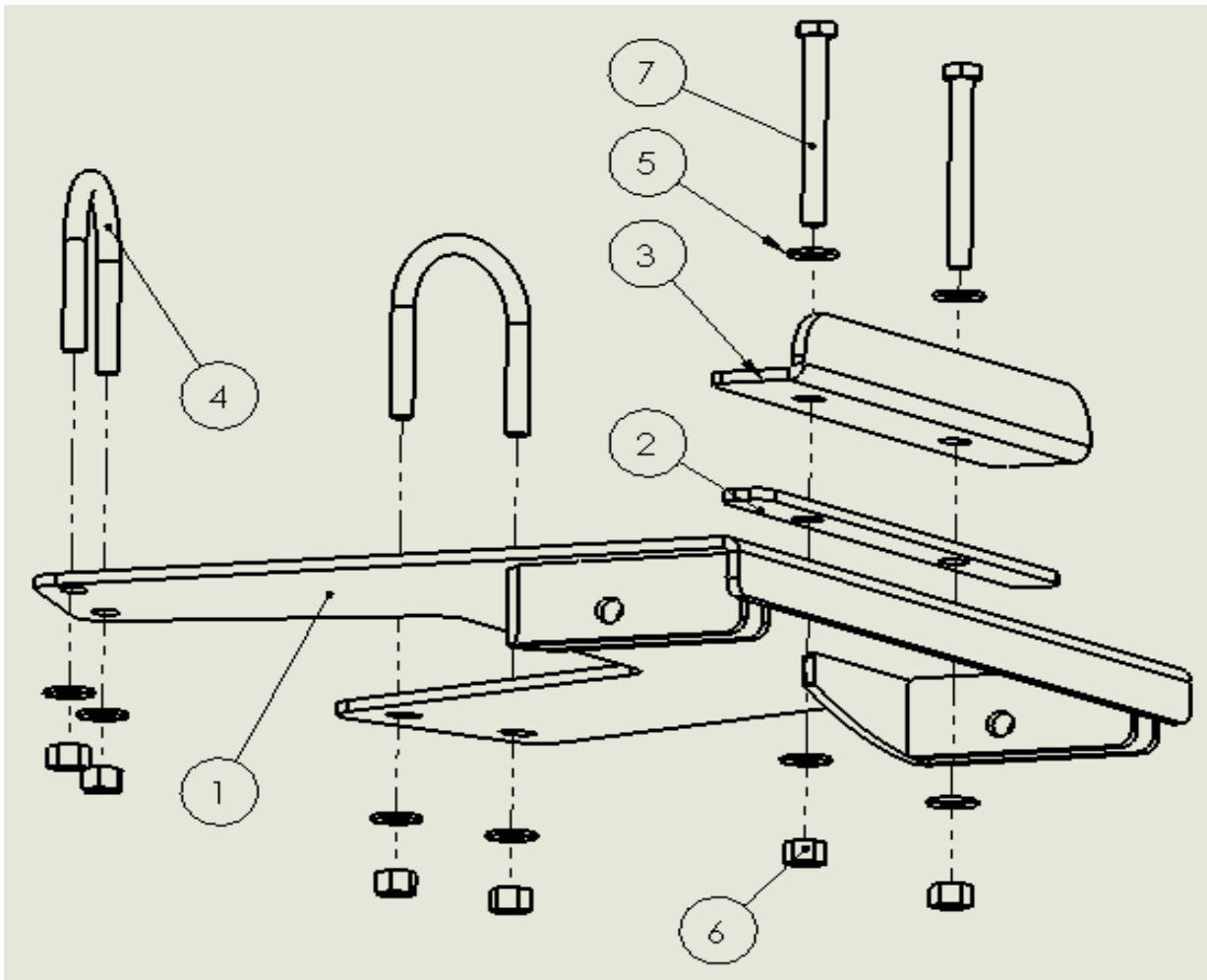



Plow Mount Assembly:

1. Locate the front A-arms of your vehicle. To the rear of the arms are two bolt holes roughly 4.75" apart. Orient the plow mount with plow attachment tabs facing the front of the vehicle and the two bolt holes aligned with the holes in the ATV underbody.
2. Locate the angled hold down bracket (Figure 1). Set the bracket atop the ATV's frame (opposite side of the plastic underbody guard) and align the two holes in the bracket with the two holes in the ATV. With the holes aligned, the 'L' portion of the bracket should face the rear.

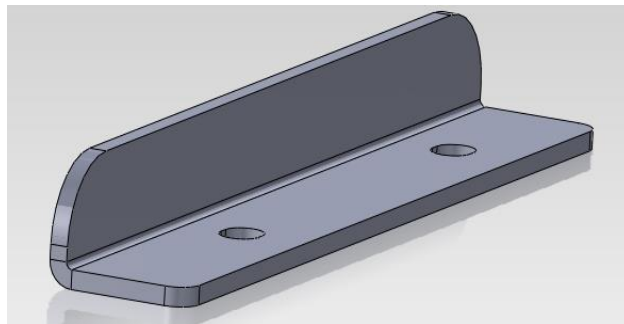

Figure 1

3. Insert the two 2.5" bolts from the top of the angled hold down bracket (Figure 2). The bolts should go through the ATV frame and down through the flat hold down bracket which sits on the underside of the ATV's plastic underbody and atop the mount plate. The bolts then make their way through the mount plate. Secure with the included 5/16" washers and nuts.

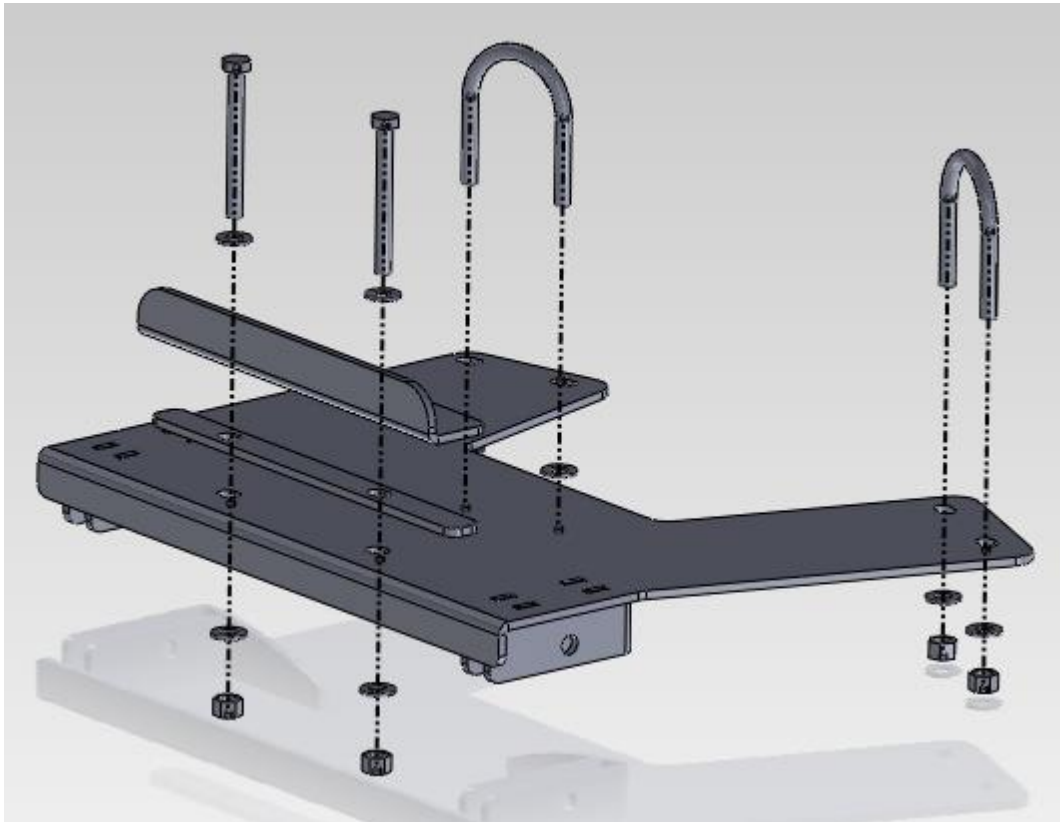

Figure 2

4. Insert the U-bolts around the ATV frame and through the mount plate, securing them with the accompanying washers and nylock nuts. Secure all bolts to 22 ft-lbs.

Plow Installation:

1. Slide the plow into position with the tubes under the ATV. Lift the end of the tube assembly into position so the holes in the tube wings line up with the 3/8" holes in the frame brackets.
2. A Phillips head screwdriver may be used to align the holes. Insert both 3/8" pins and hook the retaining clips on the ends of the pins to secure the plow to the ATV.
3. The plate should now be a permanent part of your ATV and will not interfere with clearance. The plow can be easily attached and detached on the welded u-bolt with the clevis hook on a winch or a manual lift assembly.